

building
forever
furniture

panel installation manual



invincible™

General Information

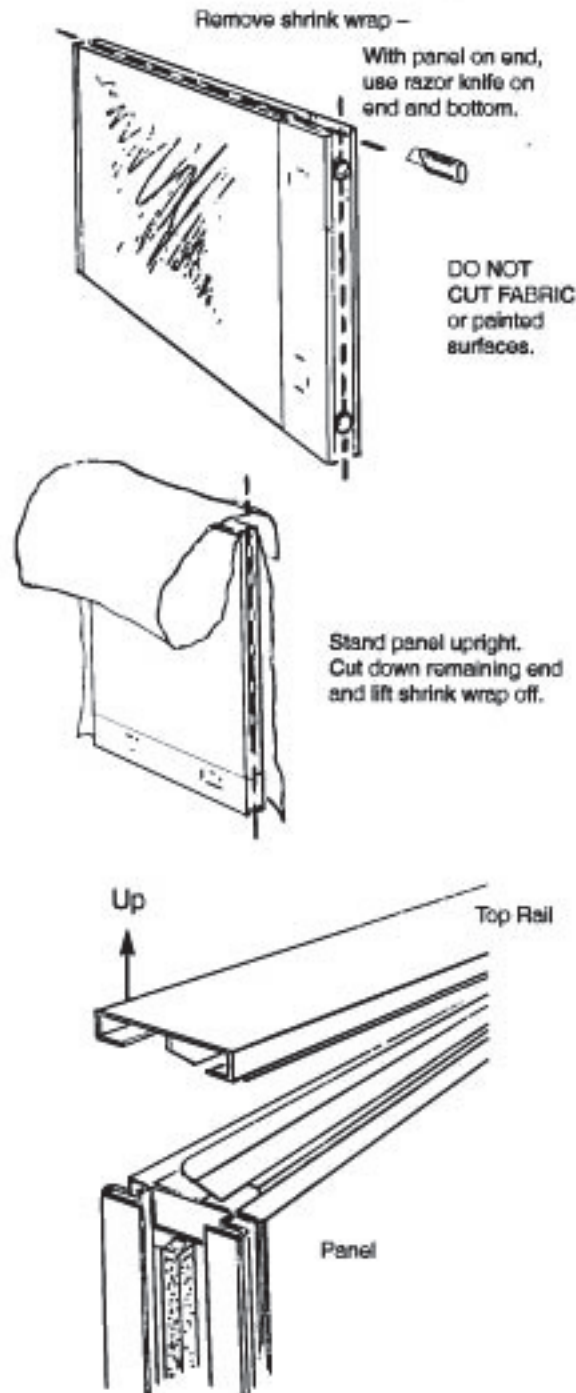

Fig. 1

1. Assemble necessary tools for installation:
 - 1/4" ratchet wrench with 3/8" socket (an electric power driver may be more desirable for larger installation)
 - 1/2" open end wrench
 - Regular screwdriver
 - Tape measure
 - Pliers
 - Level
 - Ladder or step stool
 - Inexpensive circuit tester for electrical
2. Before starting installation, check drawing layout of panels. Actual room dimensions should coincide with drawing. Examine locations of power source; they should be located on plan layout.
3. Start installation at wall, power source, or column, wherever a fit problem might occur. If panel is attached to building, see "WB" wall bracket installation instructions. If larger installation, certain areas may require assembly before others.
4. Remove panels from packing with clean hands, and place into position. Remove "Top Rail" by gripping one end and gently wiggling up and off while progressing the length of rail. USE CAUTION not to bend rail while removing. See Fig. 1.

General Information

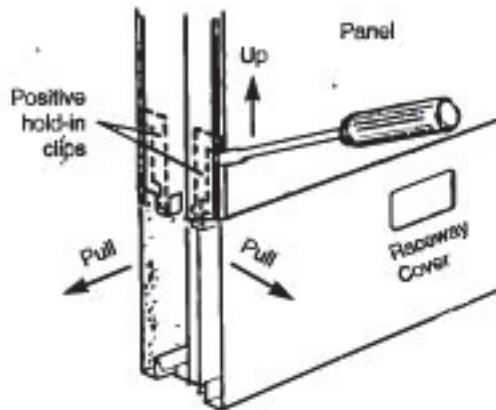
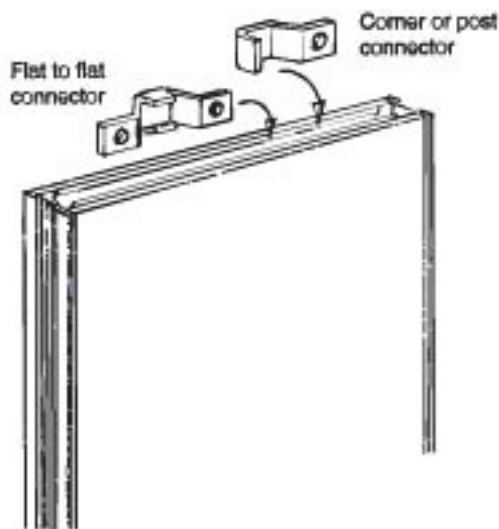

Fig. 2



5. Before installing any panel, remove "Raceway Cover" by releasing "Positive hold-in-clip" located at bottom of hang-on rail slot of each panel. Use regular screwdriver. Top of cover will release and pivot downward. See Fig. 2.
6. Stack top rails and raceway covers by size in an appropriate place; they will be installed at end of setup.
7. Panels may be numbered (number is located on panel foot) for easy identification in system layout. On larger installations where many panels are identical, the number could be placed on exterior of shrink wrap panel or numbers could be omitted completely.
8. All connecting clips are either located in top rail or on larger jobs in a box labeled small parts.

NOTE: Additional post clips are located inside each post.

Recommended Order of Installation

Step 1:	INSTALL PANELS	Page
	Post Connection	1-2
	Panel to Panel	3-4
	Mid Panel	5
	Panels of Different Height	6-7
	Trim Ends	8
	Power Pole	9
	Wall Bracket	10-11
	Door Installation	12
Step 2:	ADJUST FLOOR GLIDES	13
Step 3:	CONNECTING ELECTRICAL	14-16
Step 4:	TELEPHONE & COMPUTER LINES	17
Step 5:	INSTALL BOOKSHELVES & RDU's	18
Step 6:	INSTALL TOP TRIM & RACEWAY COVERS	19-20
Step 8:	INSTALL WORKSURFACES	21
	Convergent Worksurfaces	22
Step 9:	ATTACH UNITS TO WORKSURFACES	
	Pedestals	23-24
	Keyboards	25
Step 10:	INSTALL HORIZONTAL WALL TRACK	26
Step 12:	CARE AND CLEAN UP	27

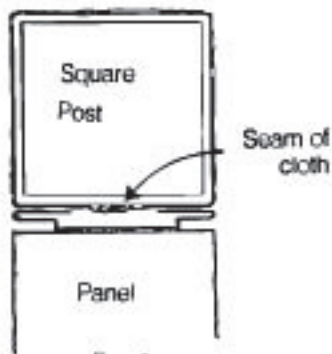

Fig. 3

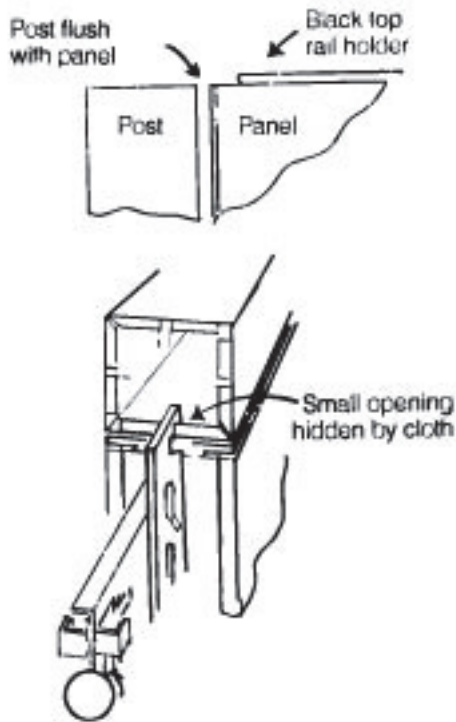

Fig. 4

Step 1: POST CONNECTION

1. Place post onto end. If post is fabric, seam should be to inside. See Fig. 3. Hold post flush with top of fabric portion of panel during assembly.

Bottom slide must be tightened before top clip is installed or post will not be in proper position.

2. Use ratchet with 3/8" socket, and tighten on bottom slide so it raises and holds post. (DO NOT over tighten as post will pull away from top of panel.) See Fig. 4.

NOTE: With square post be sure "Bottom Slide" is caught in small opening of spacers which prevent square post from sliding back and forth.

3. Continued on next page.

NOTE: ADDITIONAL POST CONNECTORS ARE FOUND INSIDE EACH SQUARE OR ROUND POST.

Step 1: POST CONNECTION, cont'd.

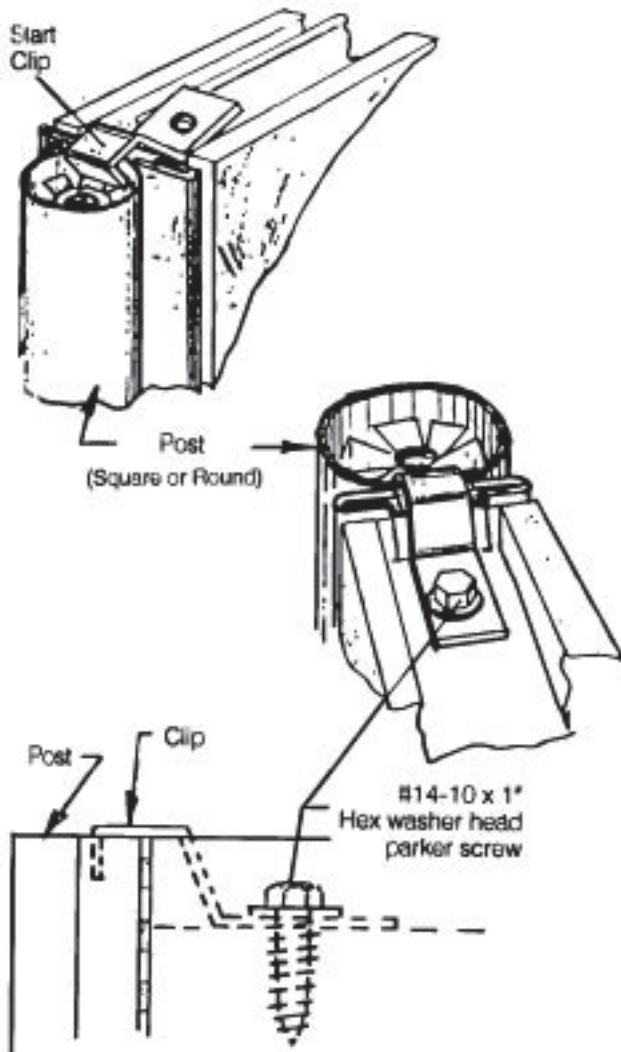

4. Remove #14-10 x 1 Hex washer head parker screw from top corner of panel where post is to be attached. Start top clip on post and push down on back end of clip until #14-10 x 1 hex washer head screw can be started. Using a ratchet, tighten clip. Top of post should be level with top of uprite. Clip should be flush with post top so top cap fits properly. If clip is on upward angle, tap down with hammer.
5. Bottom slide can now be tightened securely. Post must be centered on end of panel to prevent uneven alignment.

NOTE: ADDITIONAL POST CONNECTORS ARE FOUND INSIDE EACH SQUARE OR ROUND POST.

Step 1: PANEL TO PANEL CONNECTION

1. Put appropriate panels in place and level, eliminating any gap between. See Fig. 6.

NOTE: If panels are not leveled to same height, worksurfaces will not align properly.

2. Remove bolt and flat nut from "bottom slide." Protrude "bottom slides" of panels to be joined until they cross with black marks facing each other and the holes align. Tip of slides are offset to allow alignment of panels. Insert bolt thru both "bottom slides" and loosely turn on flat nut. DO NOT tighten. Use ratchet with 3/8" socket and draw up "bottom slides" of both panels, applying tension evenly. See Fig. 7.

3. Continued on next page.

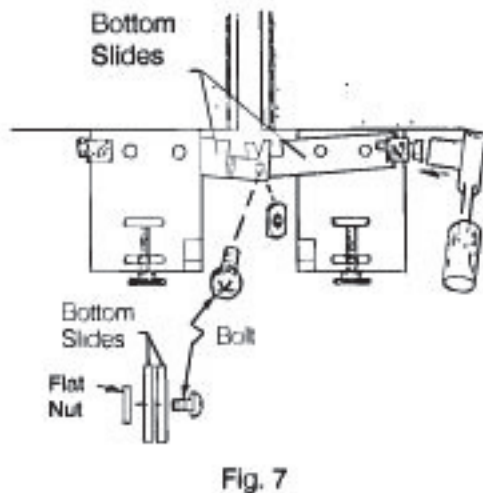
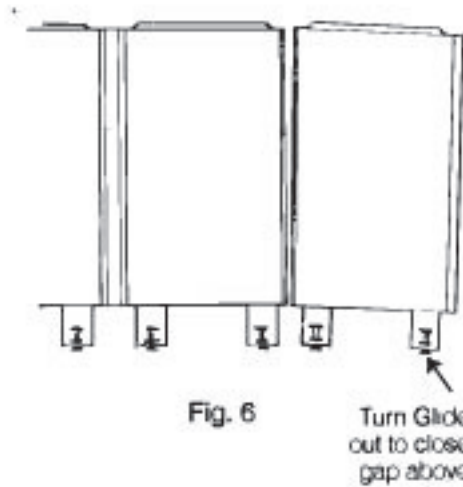

Step 1: PANEL TO PANEL CONNECTION, cont'd.

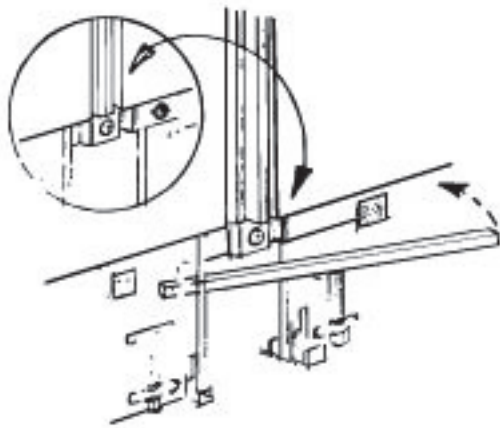

4. If panels do not align (feet may be bent from shipment), place a small pry bar between feet and bend panels into alignment, then tighten bottom slide. This is necessary for raceway covers to align.
5. Remove #14-10 x 1 Hex washer head parker screws from top corner of panels where clip is to be fastened. Push panels together so no gap exists and place top clip over joint. Start screws in holes and tighten down, alternating between screws, thus applying tension evenly. See Fig. 8.

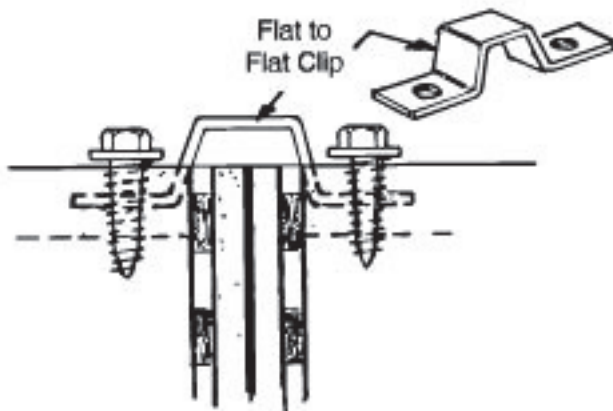

6. If clip is not flush, tap down with hammer.

Fig. 8

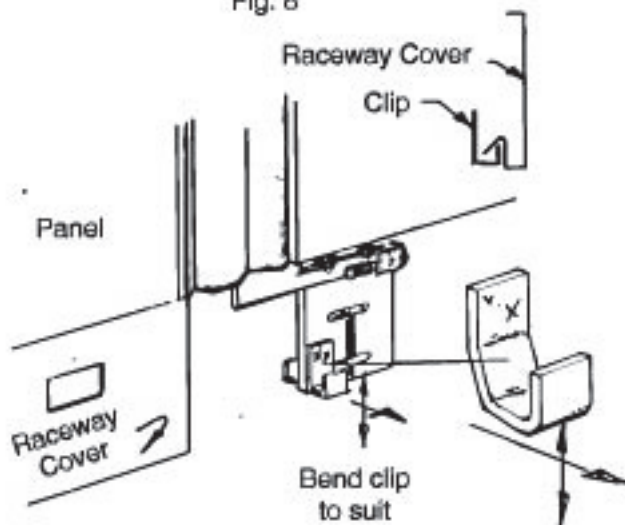

Step 1: MID PANEL JOINT

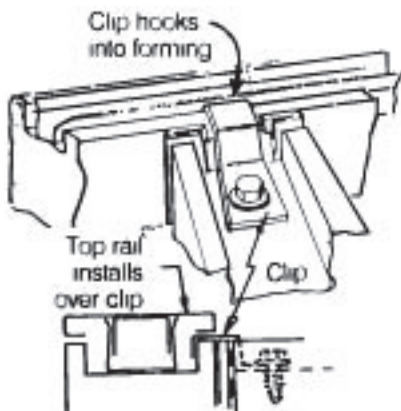
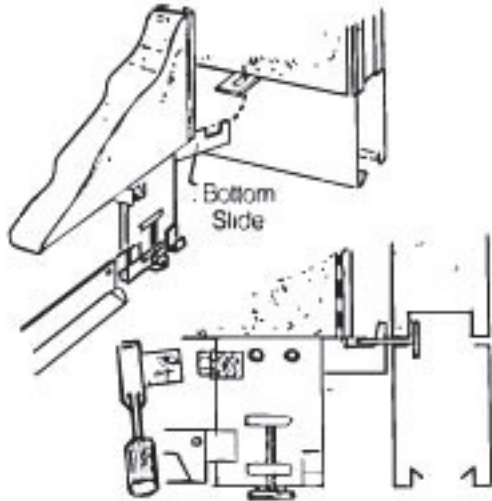
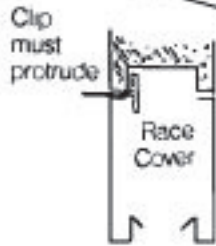
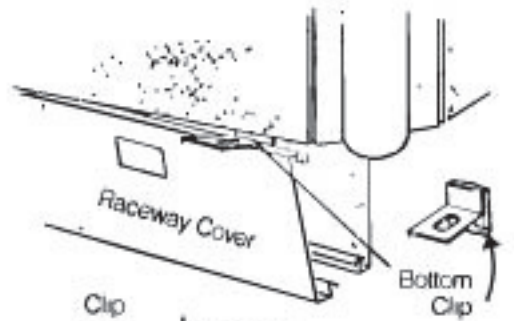

1. Take the panel that is to be the mid joint and mark the raceway cover at the point of connection.
2. Remove race cover and slide on mid joint bracket until it is by the mark.

Lock raceway cover in place. Make sure double metal of clip is UP.
3. Catch mid panel clip with bottom slide of joining panel.
4. Tighten bottom clamp until snug. DO NOT over tighten, or bottom mid panel clip will deform.
5. Use special mid panel top clip to fasten top.

Step 1: JOINING PANELS OF DIFFERENT HEIGHTS

PANEL TO PANEL

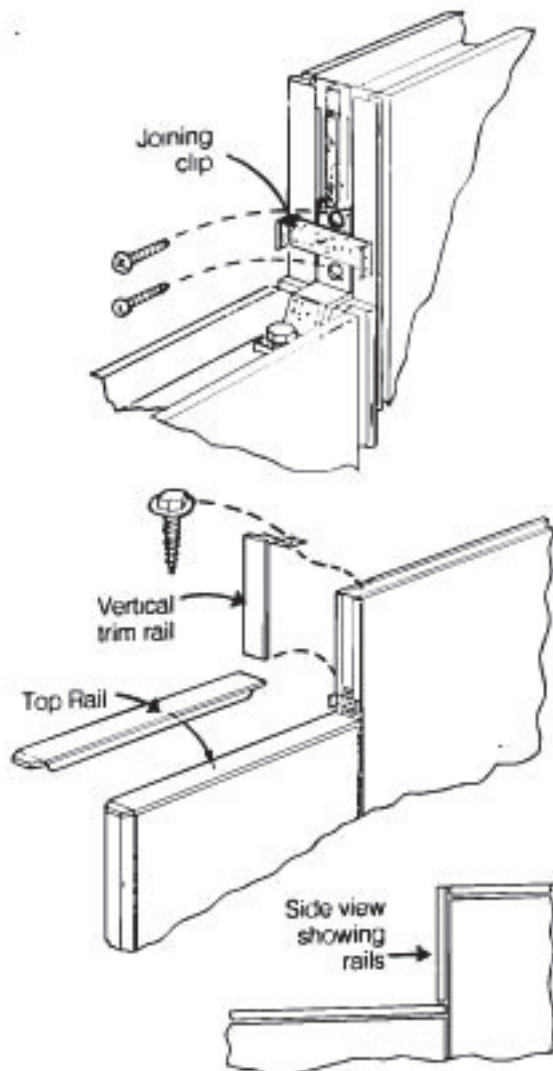

1. Taller panel has been pre-drilled at factory and is identified by a yellow sticker on the foot and side of panel that was drilled.
2. Place lower panel against higher panel. Level panels using bottom edge of fabric position as gauge.
3. Attach special joining clip to lower panel.
4. Fasten clip to taller panel using phillips head screws provided. If rearranging, use #28 dia. drill bit to make new holes for screws.
5. Install top rail on lower panel by placing appropriate type of joining or finishing end cap at one end of top rail. Insert onto lower panel.
6. Vertical trim rail may be attached by slipping bottom end of rail over protruding flanges of clip and fastening top of trim rail using hex head screw at end of panel.
7. Install top finishing rail of higher panel.

NOTE: Yellow sticker on foot and side panel denote side of panel which was drilled.

Step 1: JOINING PANELS OF DIFFERENT HEIGHTS

PANEL TO POST

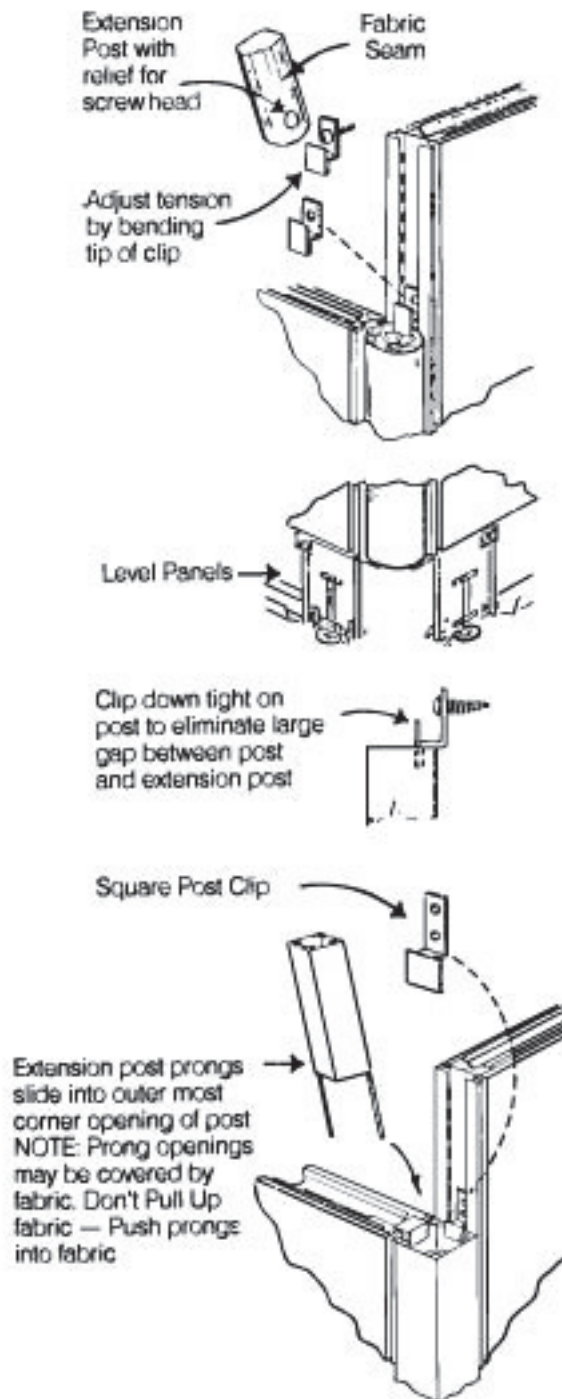

1. Connection of variable height panels always starts with the lowest height panel and its post. Attach post onto lowest panel.
2. Bring taller panel against low post. Level panel, thus eliminating any gap between post and uprite.
3. Place clip onto top of post, drill corresponding 3/16" dia. holes into uprite of panel and then fasten using phillips head screws provided.

NOTE: Post must be uptight against underside of clip to eliminate large opening between post. Standard opening is 1/16" to 3/32".

Tighten draw clip at bottom of panel thus holding post in raised position. If rearranging, use #28 dia. drill bit to make holes; using fastening clip as drilling gauge.

ROUND POSTS

4. Bring post extension down onto clip protrusion — seam of cloth post should be inside of uprite end. Tension of clip can be adjusted by bending tip of clip, using screwdriver and hammer. Attach extension post to highest panel using top clip.

SQUARE POSTS

5. Bring post extension down until the 2 prongs slide into lower post.
6. Attach extension post to highest panel using top clip.

Step 1: TRIM END

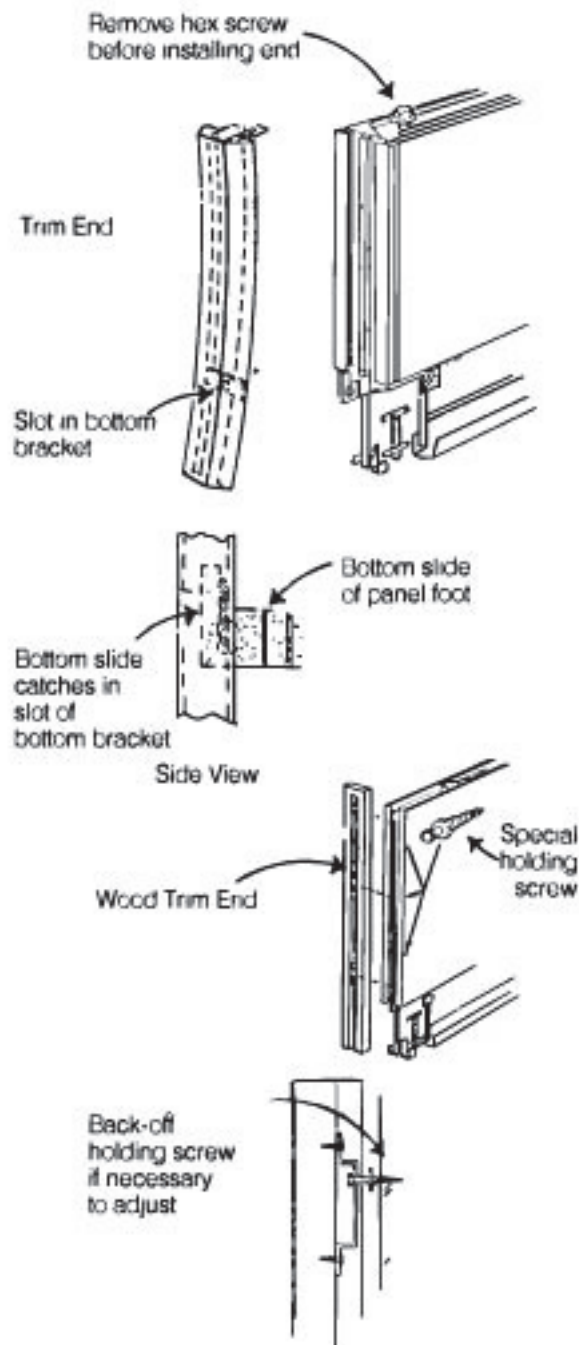

1. Trim ends are prestressed with slight bend from factory.
2. Insert bottom of trim end onto bottom bracket of panel making sure it is in slot.
3. Tighten top of trim end using hex screw.
4. Tighten bottom bracket until snug.

WOOD T-ENDS

1. Remove "top rails" from panel.
2. Remove "raceway covers."
3. Push the bottom slide, which is located on the foot assembly, until it is out of the way.
4. Hold wood T-end alongside end of panel. Attaching clips must align with special holding screws located directly across and behind foam on end of panel. Remove standard screws if necessary and insert special holding screws.

Replace foam around newly inserted holding screws.

NOTE: To adjust tension on wood T-end, back out special holding screws until T-end slips onto them easily without feeling too loose.

5. Replace "top rail."
6. Replace "raceway covers."

Step 1: POWER POLE

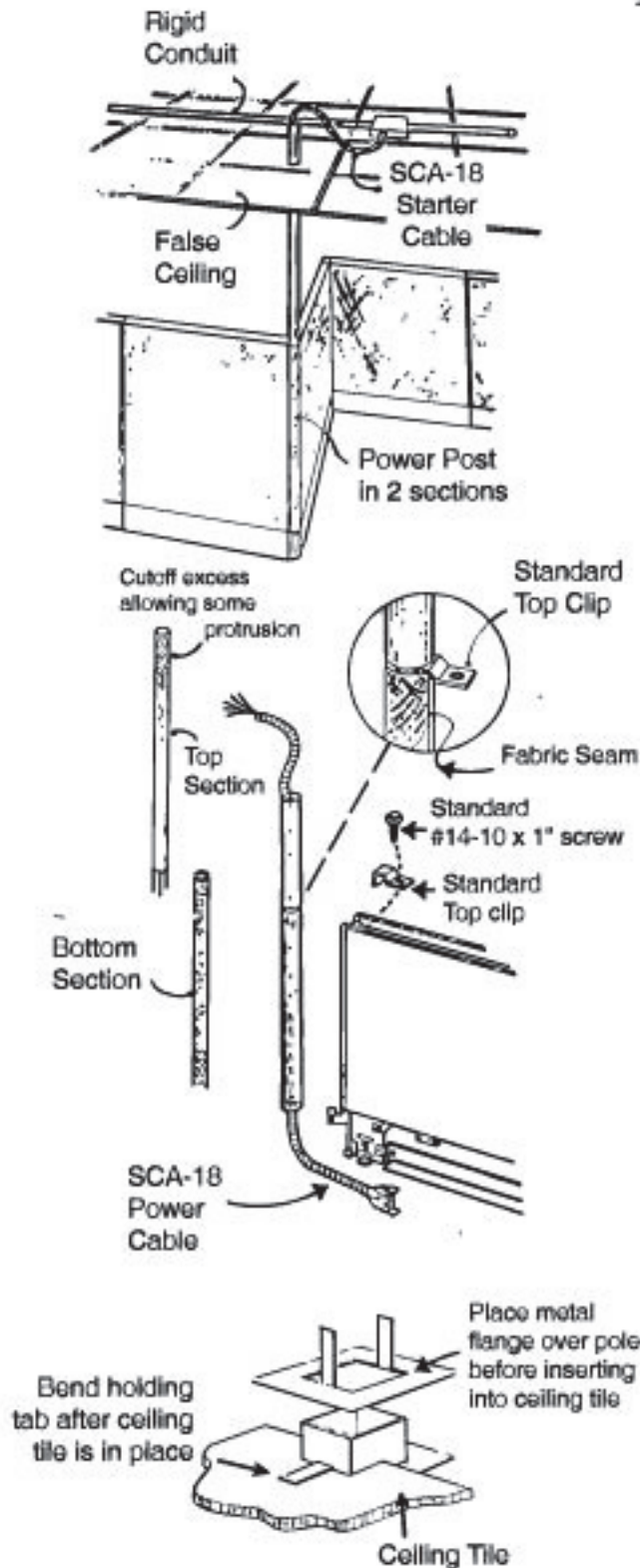

1. Using level and pole, mark the ceiling tile and cut hole to match the pole.
2. Cut pole to proper length (about 6" above ceiling tile.)

Drill 3 to 4 holes in top of the pole.
Remove all burrs from cutting and drilling.

3. Place metal flange on pole.
4. Insert pole through ceiling tile and mate with lower post.

NOTE: If using round pole, make sure star insert of lower post is removed. To remove star insert, knock sideways with hammer and screwdriver and pull it out with a pliers.

5. Using wire, fasten top of pole to ceiling struts.
6. Feed a small rope or cord through pole. Pull SCA-18 from bottom to top. Cable plug end of SCA-18 will not fit through pole. Other cables may be fed from top to bottom.

Step 1: INSTALLATION OF "WB" WALL BRACKET

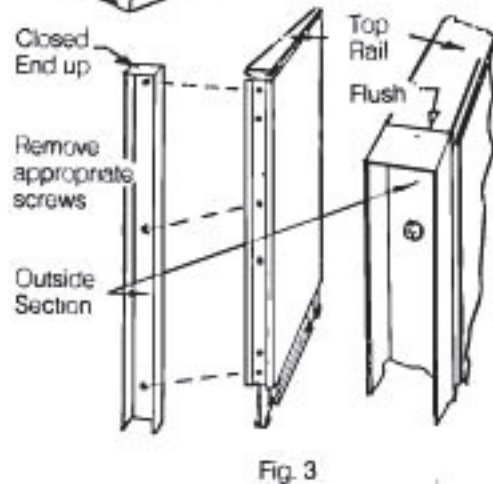
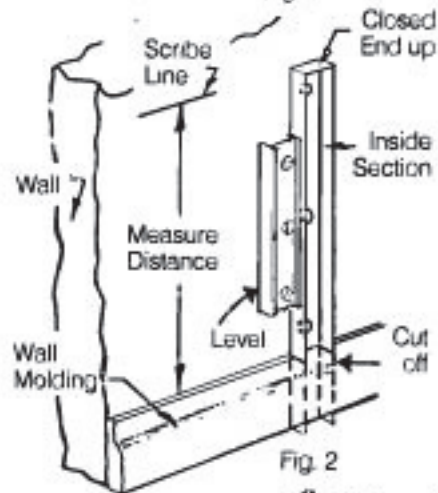
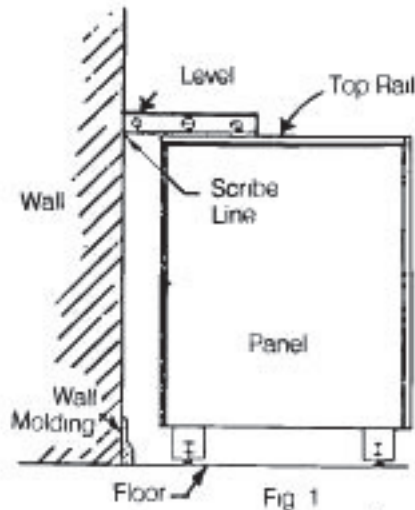

1. Place panel into position and level.
2. With "top rail" on panel, place level across panel to wall and scribe line with pencil. See Fig. 1.

NOTE: Be sure panel glides have been adjusted to keep panel as low as possible. Do this by starting with panel glides all the way in and adjusting out until level.

3. Measure distance from scribe line to floor molding, and cut off inside section of wall bracket. See Fig. 2.

NOTE: If wall does not have molding, cutting is not necessary.

4. Secure cut off section of inside wall bracket to wall. Use level to assure bracket is vertical. Because of the variety of wall construction, hardware for securing panel wall bracket to wall must be supplied by installer to suit conditions.

5. Attach outside wall bracket section to panel by standing bracket along side of panel. Line up appropriate holes in bracket with corresponding screws in uprite, remove these screws, move wall bracket into place, attach bracket using #10 x 1", round head screws provided in uprite. See Fig. 3.

6. Wall bracket should be flush at top with top rail of panel. See Fig. 3

7. Continued on next page.

Step 1: INSTALLATION OF "WB" WALL BRACKET, cont'd.

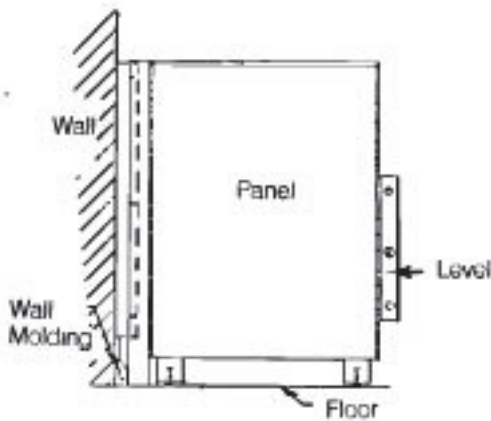

Fig 4

8. Place panel which has WB bracket attached, over inside section (already attached to wall) until contacting wall base molding. See Fig. 4.
9. Level panel and drilling 4 - 1/8" diameter holes along center line of wall brackets. 2 holes per side. See Fig. 5.
10. Lock the 2 sections of WB brackets together by screwing 4 - #6 x 3/8" screws into 1/8" holes. See Fig. 5.

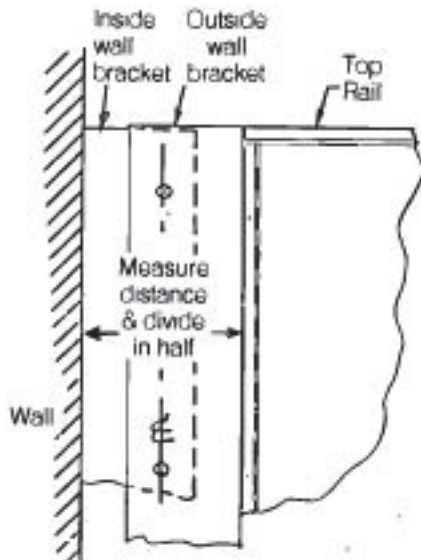

Fig 5



(a)

#6 x 3/8"
Binder head
Type "AB"
Sheet metal screws



(b)

#10 x 1"
Type "A"
Round head screws

Step 1: DOOR INSTALLATION

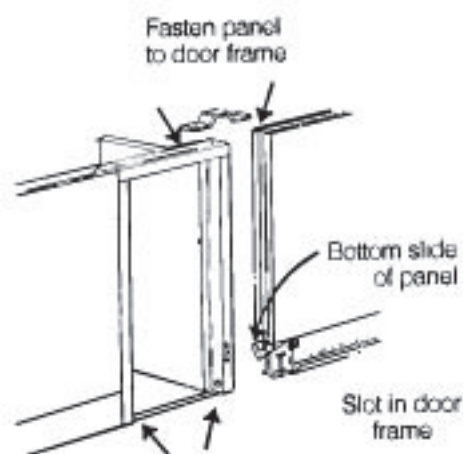

Loosen threshold screws slightly — Push down into carpet and retighten

DOOR INSTALLED BETWEEN 2 PANELS

1. Slide panels apart to allow enough room for bottom slide of panels to engage in slot of door frame.
2. Tighten bottom slides making sure top of door frame is even with top of panel.
3. Use top clips; fasten panel to door frame.
4. Adjust panel glides to even seam around door.
5. Loosen threshold; push down into carpet and retighten.

DOOR INSTALLED BETWEEN POST AND PANEL

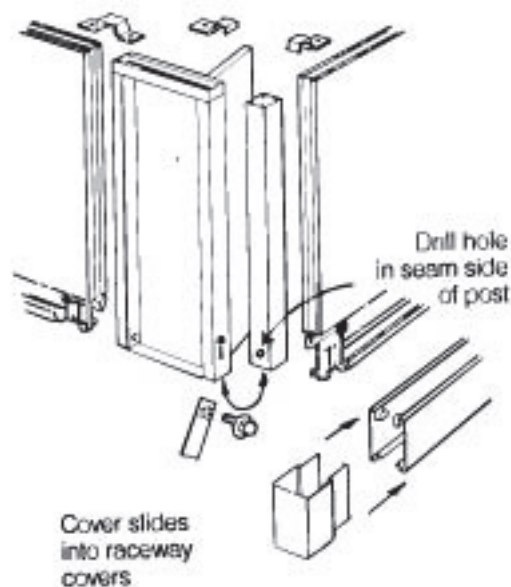

1. Making sure door swing is correct, fasten post to door frame by drilling 5/16 hole 3/8" up from bottom and center of post. Bolt post to door using special nut and bolt provided. Fasten top of post using a standard top clip. If a second door is mounted in the same post, attach that door to post at this time.
2. Place door in proper position against abutting panel and fasten door vertical uprite to panel using standard method of attachment.
3. Engage bottom panel slide into door frame and fasten. Fasten top of frame using standard clip.
4. Adjust panel glides to even seam around door.
5. Loosen threshold; push down into carpet and retighten.
6. Install special raceway corner cover after raceway covers are installed on panels.

Step 2: ADJUST FLOOR GLIDES

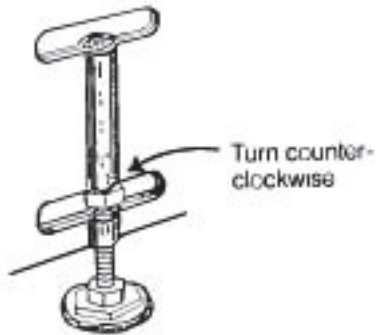

1. Wherever possible, raise extended glide into panel foot until all panels are as low as possible.
2. Next, lower the glides that are not touching the floor until all glides are snug to floor.
3. Tighten nuts together so as to hold glides in place.
4. Repeat for every office or group of panels.

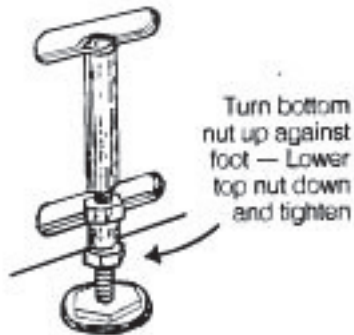

Step 3: INVINCIBLE 8 WIRE INSTALLATION

The power system is a 20 amp 8 wire plug-in type power distribution system with 4 individual circuits providing a practical alternative to high cost, labor intensive methods of providing electrical outlets and task lighting circuits in open plan furniture.

The pre-wired panels offer flexibility which can be easily and reliably interconnected at the site, or retrofitted with duplex receptacles in the field after installation.

The system allows for tapping off of energy saving task lighting as well as providing the capability for 2 optional dedicated circuits for data processing terminals as required:

- Four available circuits accommodate up to 13 duplex receptacles per circuit.
- All electrical components are underwriter laboratory approved.
- Variety of power entry equipment available for power source situation.
- 15 amp duplex receptacles have back to back capability and are interchangeable.
- If requested, the panels are pre-wired at factory except where local electrical code prohibits.

1. **DIVIDED POWER RACEWAY** – Used to divide communication and computer cables from higher voltage electrical cables.

2. **DUPLEX RECEPTACLES** – Provides two electrical outlets per receptacle, can be ordered in 4 different circuits:

- Circuit 1 - Utility Circuit
- Circuit 2 - Utility Circuit
- Circuit 3 - Utility Circuit
- Circuit 4 - Computer Circuit

3. **INTERCONNECTING CABLE** – Supplied with electrified panel, used to pass power from panel to panel.

4. **POWER CHANNEL** – Supplied with electrified panel, used as a pass thru or as a power assembly when receptacles added. 24" and 30" panels have 1 receptacle per side; all other panel sizes are capable of 2 receptacles per side.

5. **RACEWAY COVERS** – Metal face plates, used to cover electrical raceway. Supplied with panel (completely removable).

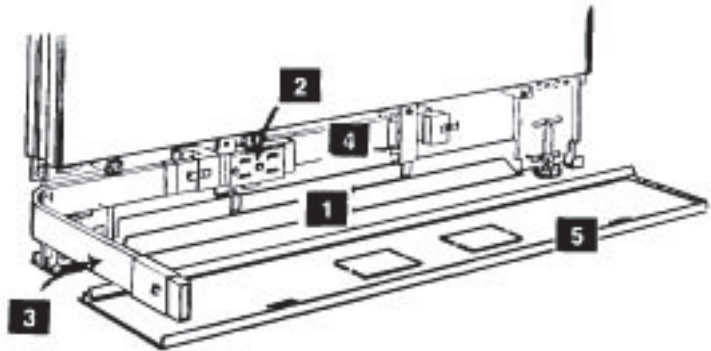

The 8 wire system can have up to 4 circuits depending on the type of power source available. The drawings below show the combinations of standard circuits available.

Building Power Source
120/240 V single phase

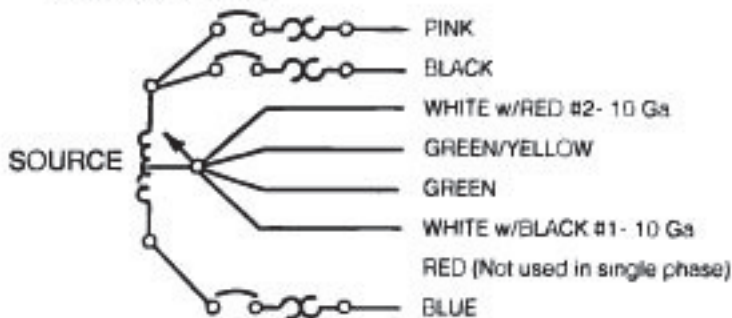

- Circuit 1 - Utility Circuit
Used with 3 phase or single phase
- Circuit 2 - Utility Circuit
Used only with 3 phase WYE power
- Circuit 3 - Utility Circuit
Used with 3 phase or single phase
- Circuit 4 - Computer Circuit
Used with 3 phase or single phase

- Circuit #1
HOT – Black
NEUTRAL – White w/Black #1 10 Ga.
GROUND – Green
- Circuit #2
Cannot be used with single phase
- Circuit #3
HOT – Blue
NEUTRAL – White w/Black #1 10 Ga.
GROUND – Green
- Circuit #4 I.G.
HOT – Pink
NEUTRAL – White w/Red #2 10 Ga.
GROUND – Green/Yellow

Step 3: 8 WIRE INSTALLATION

Building Power Source
120 240 V Delta

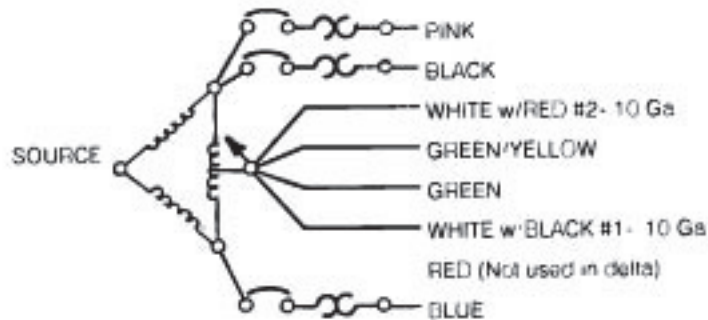

Circuit #1

HOT - Black
NEUTRAL - White w/Black #1 10 Ga.
GROUND - Green

Circuit #2

Cannot be used with delta source

Circuit #3

HOT - Blue
NEUTRAL - White w/Black #1 10 Ga.
GROUND - Green

Circuit #4 I.G.

HOT - Pink
NEUTRAL - White w/Red #2 10 Ga.
GROUND - Green/Yellow

Building Power Source
120 208 V WYE

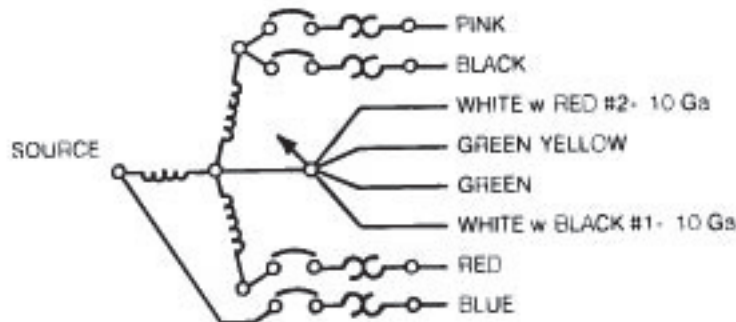

Circuit #1

HOT - Black
NEUTRAL - White w/Black #1 10 Ga.
GROUND - Green

Circuit #2

HOT - Red
NEUTRAL - White w/Black #1 10 Ga.
GROUND - Green

Circuit #3

HOT - Blue
NEUTRAL - White w/Black #1 10 Ga.
GROUND - Green

Circuit #4 I.G.

HOT - Pink
NEUTRAL - White w/Red #2 10 Ga.
GROUND - Green/Yellow

Step 3: ELECTRICAL CONNECTION

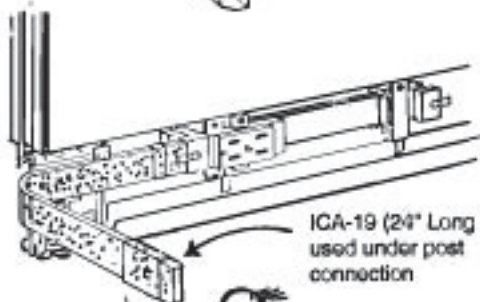
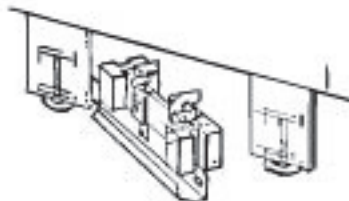
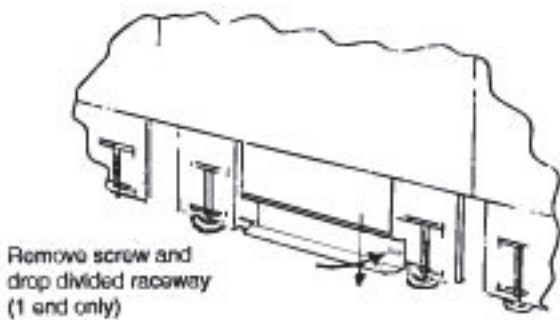

There are other combinations available such as 2 dedicated circuits (consult factory).
To install the SCA-18 power start cable erect panels and assemble power post. Once the power post is in place, feed the SCA-18 cable from bottom to top. (Note: Plug on end of SCA-18 will not fit through power post.)

Plug SCA-18 into nearest open interconnecting cable plug.
Interconnecting Cable Plug



DO NOT Plug SCA-18 into receptacle location

PLUG INTO THIS END

After SCA-18 is installed, the electrician can wire to building source.

To install base power feed erect panels and snap all electrical components together. Find location where power is to be installed.

Remove raceway cover and feed end of cable through knockout.



1. If power channel is not factory installed, install power channels in appropriate panels at this time.
 - a) Remove 1 screw from divided raceway end and pull race toward you, about 8". Slide on power channel and reinstall divided race.
2. Install receptacle in proper place and fasten with #6 x 5/8 screw.
3. Snap interconnecting cable to power channel. Use 21-3/4" length cable for panel to panel and 24" length cable for post connection.

Do not connect or disconnect interconnecting cables when system is powered.

4. After all interconnecting cables are fastened, connect either the SCA-18 power feed or the E2 power feed.

SCA-18 – Make sure circuit breakers are off. Snap end of SCA-18 to power channel and fasten ground wire. Do not fasten SCA-18 into receptacle location – it will not lock into place.

E2 – Before electrician wires E2 to the building source, feed the end of wire through the appropriate knockout in raceway cover. Then snap E2 in place of receptacle and fasten with screws. Put raceway cover on and have electrician wire E2 to building source.

Step 4: STRING TELEPHONE and COMPUTER WIRES

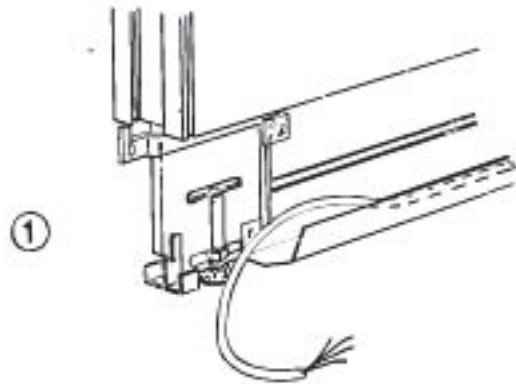

1. Run wires through divided raceway allowing some slack at corner of panels.
2. For cables to exit panel, simply lay cable on the floor at end of the divided raceway. When raceway covers are put on, cable will be on outside of panel.
3. The telephone or computer technicians can now wire jacks to end of wires.

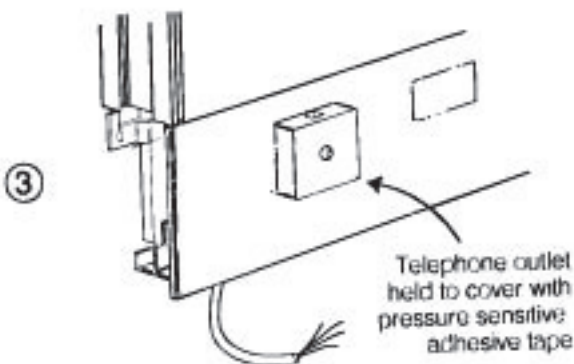
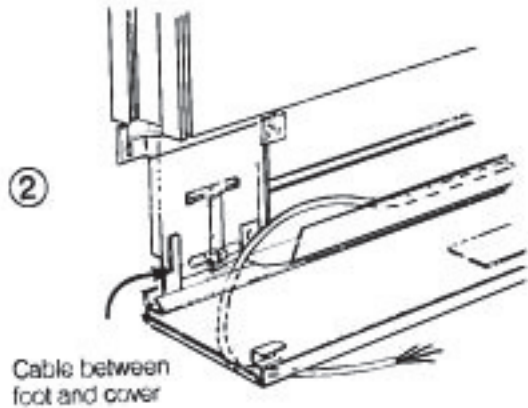

Step 5: ATTACH BOOKSHELVES and RDU's

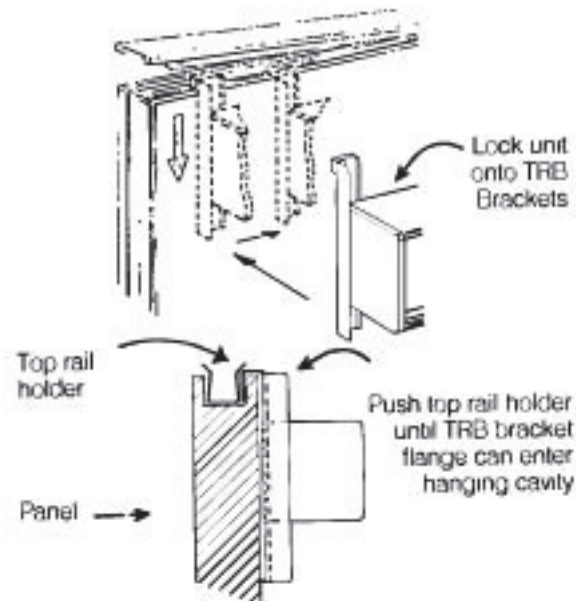
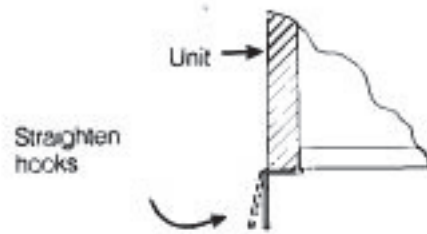
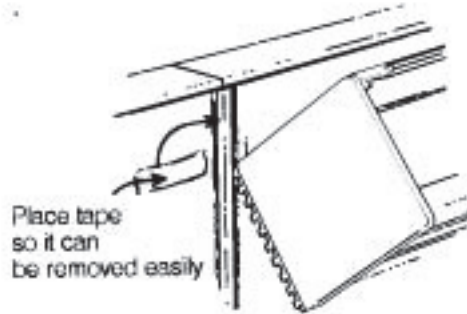

1. Locate the proper width unit to match panel. Determine the height unit is to be installed and mark with a piece of tape. To install unit, tilt on backward angle so top hook falls into slot. Then bring down the unit so all the hooks engage into slots. Make sure self-locking mechanism engages.
2. If unit does not snap into place, hooks may have been bent inward due to shipping. Take pliers and bend hooks on slight outward angle and install.
3. If top rail hanging brackets are to be used, snap TRB to unit first, then hang unit off of hidden top rail.

Step 6: INSTALLATION of TOP TRIM and RACEWAY COVERS

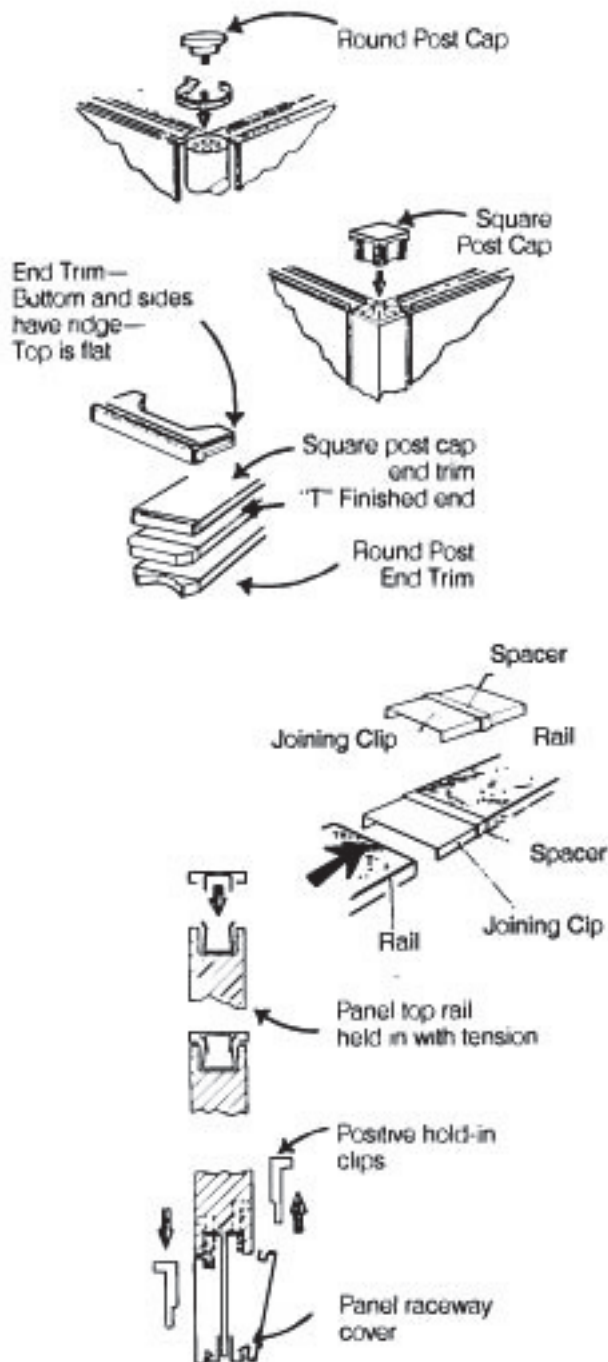

1. Attach all post caps first. Then replace top rails after inserting proper plastic end trim.

In a straight run of 4 panels or more, the top rail joining clip spacer may have to be removed. In such cases butt ends of rails tightly together.

Joining clips are taped to the inside of the raceway cover or in a separate box marked "**Small Parts.**"

2. Attach raceway covers by placing offset formations (bottom channel of cover) over clips on panel foot. Pivot cover upward until it slips over clips on the panel foot.

Lift positive hold-in-clip and raise cover until flush with front of panel. Lock cover in place by lowering positive hold-in clips into receiver on cover.

3. Continued on next page.

Step 6: INSTALLATION of TOP TRIM and RACEWAY COVERS, cont'd.

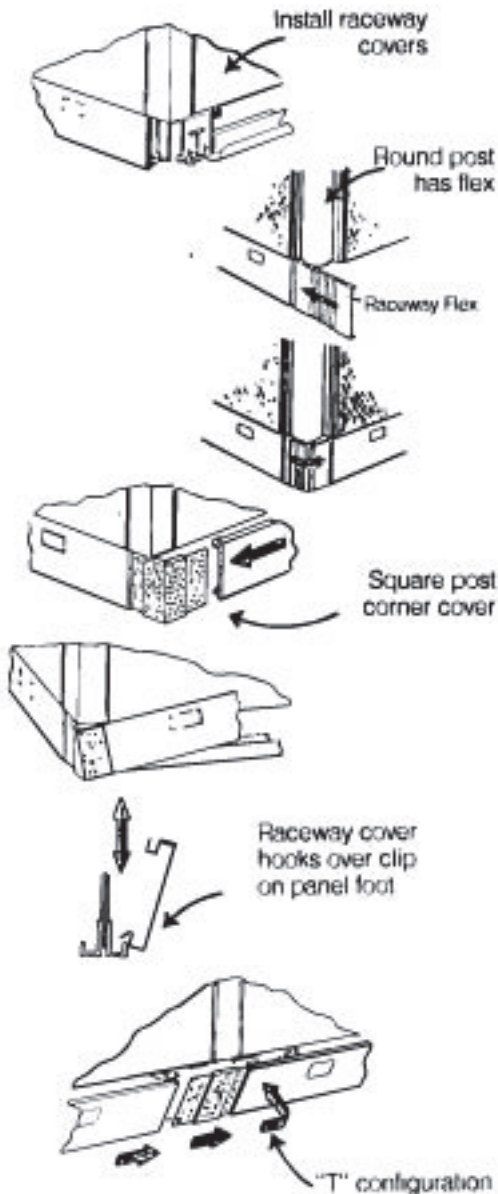

CORNER COVERS

4. Placement of corner cover or raceway flex accomplished by inserting one end into raceway cover already in place.

Opposite end of corner cover or flex inserts into raceway cover being installed. Then lift raceway cover until "offset formation" (channel at bottom of cover) slips over clips on the panel foot.

Continue to install as described above, and lock into place.

5. T-Configuration has same procedure for installation as corner cover.

Step 8: INSTALLING WORKSURFACES

To lock into place, tab must be all the way in

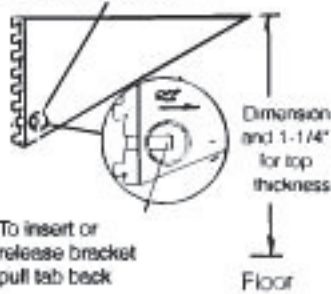

To insert or release bracket pull tab back

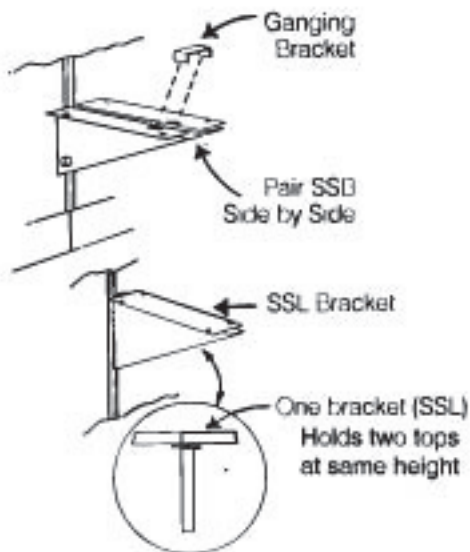
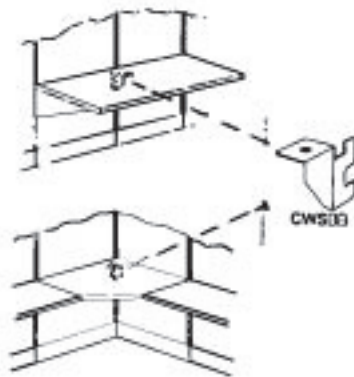

1. Attach "WS" worksurface brackets onto panel by inserting hooks of bracket into uprite hang-on slots of any panel.
2. Determine correct height by measuring from floor to top of bracket and adding 1-1/4" for top thickness, *before* locking brackets into place.
3. Tops longer than 60" and/or corner tops should receive additional support by placing a CWSBB bracket into middle or corner uprite.
4. Place optional ganging bracket into slots of WS's or use SSL bracket.
5. Temporarily position all tops in workstation. Check sizes and colors. If necessary, move panels to eliminate gap between tops and panels. Fasten tops to brackets using #10 x 3/4 screws.

Step 8: CONVERGENT WORKSURFACES

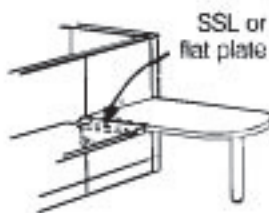
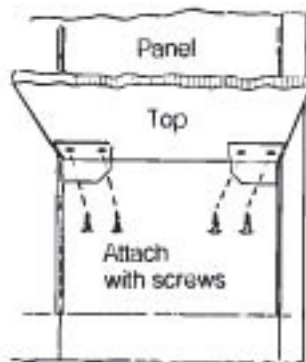
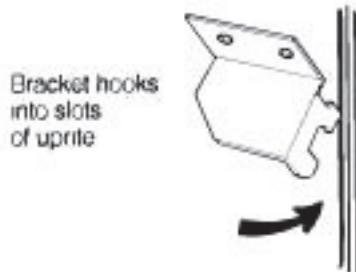

1. Lay work surface on floor and fasten leg to work surface using #6 x 3/4 screws which are provided.
2. Attach convergent work surface mounting bracket to panel at correct height.
3. Set work surface on bracket and fasten with screws.
4. Using flat connecting plate or SSL support bracket which is ordered separate, fasten convergent work surface to a perpendicular standard work surface. This helps solidify the setup.

Step 9: ATTACHING PEDESTALS to WORKSURFACES

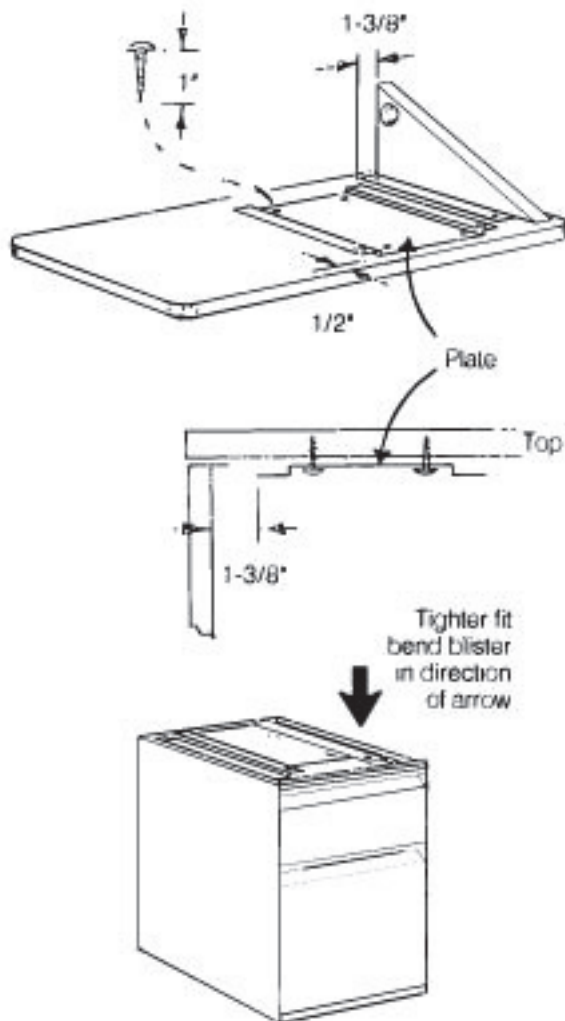

HANGING PEDESTALS USING HANG-ON PLATE

1. Install hang-on plate with holes in flange portion of plate 1/2" away from front edge of worksurface and minimum of 1-3/8" from "WS" cantilever support. Secure plate with #10 x 1" phillips head screws.

CAUTION: Do not use screws **smaller** or **larger** than #10 x 1".

Slide hanging file unit onto attached plate until blisters of channel brackets, on top of pedestal, lodge in holes of plate flange.

Tighter fit obtained by bending blister portion of Z-channel brackets, towards top of unit.

Step 6: ATTACH PEDESTALS TO WORKSURFACES

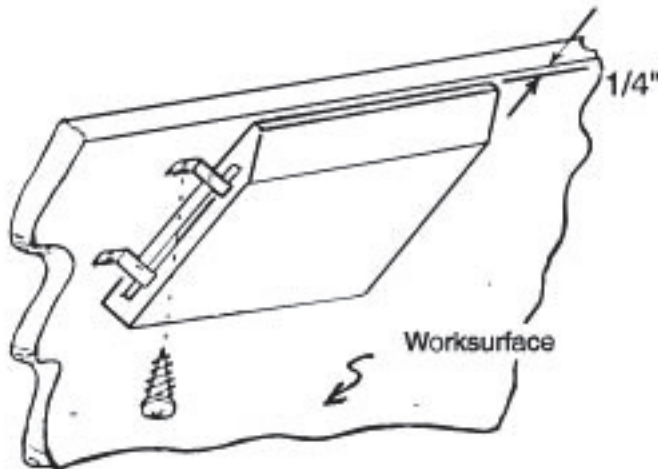
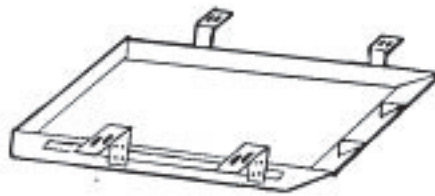
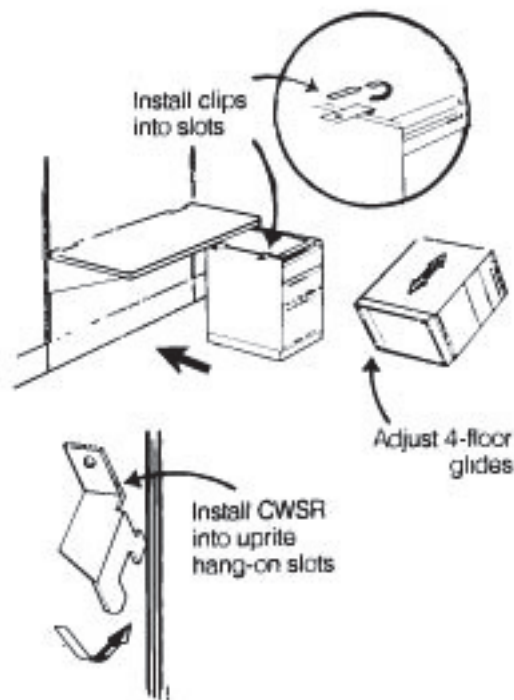

FREE STANDING PEDESTAL USING WORKSURFACE SUPPORT BRACKETS

1. With worksurface in place, adjust floor glides of pedestal so that unit slides tightly under worksurface.
2. Slide 2 clips between flat steel plain top and top of jacket body. Clips face knee-space side of pedestal.
3. Fasten clips to underside of worksurface with #10 x 3/4 screws.

WHEN WORKSURFACE SUPPORT BRACKETS ARE OMITTED:

1. Repeat same as #1 above.
2. Install CWSL or CWSR at required height in place of SSB bracket.
3. Repeat same as #2 above.
4. Repeat same as #3 above.

ATTACHING PENCIL DRAWERS

1. With worksurface in position, place pencil drawer under worksurface approximately 1/4" in from front edge of top.
2. After pencil drawer is square to worksurface, secure drawer with (8) - #10 x 3/4" screws.
3. Slide mechanism back and forth testing for binding.

Step 9: INSTALLING KEYBOARDS

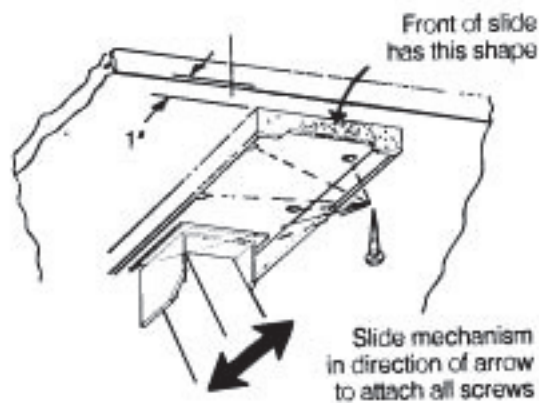

ARTICULATED KEYBOARD INSTALLATION

1. The following procedure is best performed before worksurface is attached; however, installation can be accomplished with worksurface in place.
2. Place front edge of slide mechanism 1" in from front edge of worksurface and attach using six screws. **NOTE:** Slide mechanism back and forth to locate all attaching holes.

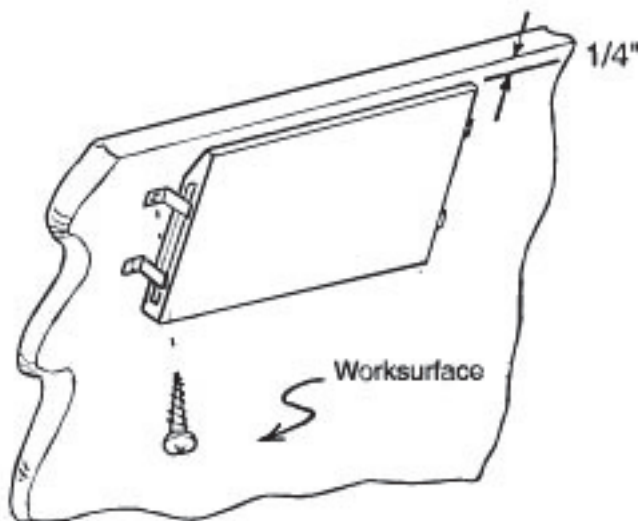
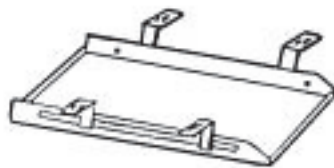

KS-5 TRAY INSTALLATION

1. The following procedures are best performed before worksurfaces are attached. However, installation can be accomplished with worksurfaces in place.
2. Place keyboard under worksurface 1/4" in from front edge. Once keyboard is square to worksurface, secure keyboard with (8) - #10 x 3/4" screws.
3. Slide mechanism back and forth testing for binding.

Step 10: INSTALL HORIZONTAL WALL MOUNT TRACK

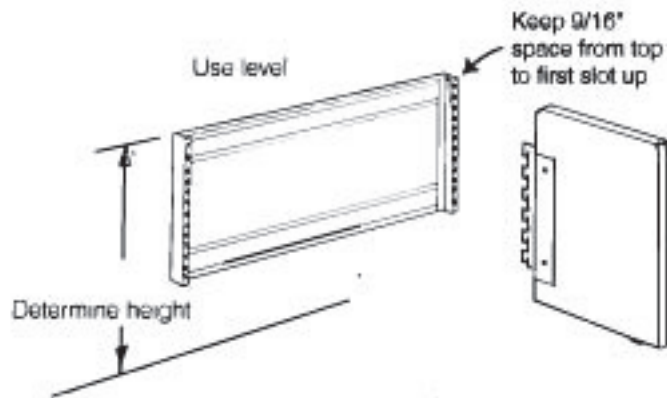

1. Due to varying wall conditions, the attaching hardware is not included. "HWT" is used when support is required from a permanent building wall.
2. Determine proper height, mark location on wall. Anchor "HWT" using appropriate fastening for type of wall or surface involved. Mounting "HWT" to drywall is not recommended unless fastening into wall studs.
3. Hanging worksurfaces off "HWT" is not recommended. Use "SEP" support end panels instead of worksurface support brackets.

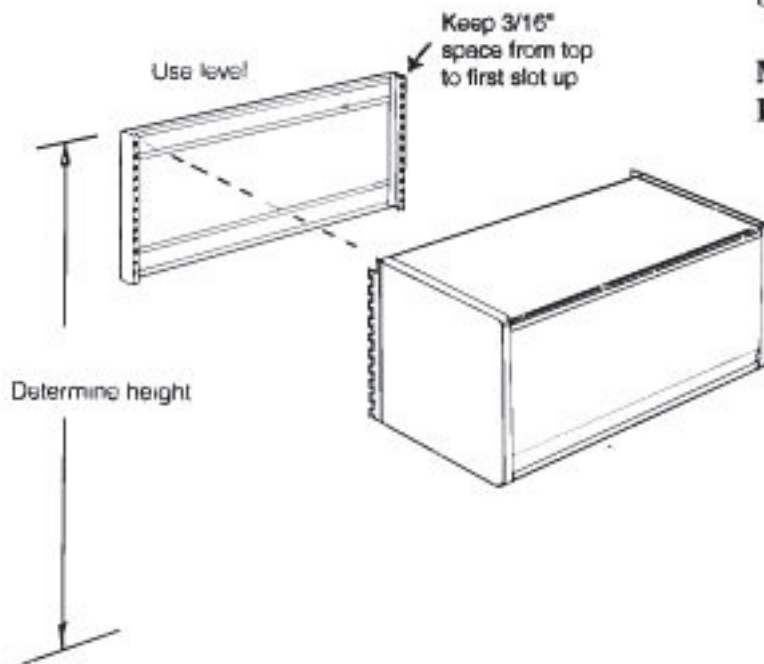

Mounting more than one bookshelf or RDU per "HWT" is not recommended.

Step 12: CARE and CLEANING of INVINCIBLE SYSTEMS FURNITURE

1. To clean worksurfaces, use windex or other spray cleaner and wipe with soft cloth. For tough stains on the laminates or vinyl edge, soft scrub with bleach works well. Solvents should never be used without first checking to see if it melts or deforms the vinyl edge.
2. To clean fabric panels vacuum when needed. To remove stains, first try K2R spot remover or a similar product. Follow the instructions on the commercial product label. If commercial products do not work, consult a local interior cleaning service.
3. Scratches in paints can be touched up by ordering touch-up paint from Invincible.
4. Any loose threads should be cut off. NEVER PULL loose threads.
5. Any racecovers that accidentally come off should be reinstalled immediately.
6. Replacement task light bulbs can be purchased at any store which handles lighting.
7. To replace damaged fabric, consult factory for replacement kits.
8. RDU door track should be sprayed with WD-40 once per year. All other drawers are lubed for life.



invincible™

872 South 26th Street
PO Box 1117
Manitowoc, WI 54221-1117

(V) 877 682 4601
(F) 920 683 2970

www.InvincibleFurniture.com
Sales@InvincibleFurniture.com

building forever furniture